

THE SCHELL SOCIETY EXHIBITION

& tradition[®]
COPENHAGEN

VISIT
US
AT
ANDTRADITION.COM

AND

JOIN
US
AT
FACEBOOK/ANDTRADITION





INDEX.

PAGE 06.	THE NORDIC HERITAGE
PAGE 12.	HOW WE PRODUCE
PAGE 16.	MASS LIGHT
PAGE 17.	HOOF TABLE
PAGE 20.	RAFT STOOL HIGH AND LOW
PAGE 22.	SHUFFLE TABLE
PAGE 24.	SPINNING LIGHT
PAGE 25.	RAFT TABLE
PAGE 28.	BLASTED
PAGE 29.	TIVOLI
PAGE 32.	FLOWERPOT VP3
PAGE 33.	MEGA BULB
PAGE 34.	MILK
PAGE 35.	TOPAN
PAGE 36.	HOW WE THINK
PAGE 40.	FLOWERPOT VP1 AND VP4
PAGE 41.	TRASH ME
PAGE 42.	SLICE
PAGE 44.	BELLEVUE
PAGE 47.	BELLEVUE AJ2
PAGE 48.	BELLEVUE AJ3
PAGE 49.	BELLEVUE AJ4
PAGE 50.	HOUSE OF THE FUTURE
PAGE 52.	LIGHTING
PAGE 54.	FURNITURE
PAGE 55.	COLOURS

&TRADITION.

**THE NORDIC HERITAGE
IN CONTEMPORARY DESIGN**

CRAFT MEETS ART. FUNCTION
MEETS FORM. MATERIAL
MEETS POTENTIAL. THIS IS
OUR NORDIC TRADITION AND
HERITAGE. &TRADITION AIMS
TO BRIDGE THESE VALUES
TO CONTEMPORARY DESIGN,
RESHAPING, REDEFINING
AND REINVENTING
MATERIALS, TECHNIQUES
AND FORMS. &TRADITION
COVERS THE MASTERS OF
YESTERDAY, THE LEADING
DESIGNERS OF TODAY AND
THE TALENT WHO MAY
CREATE THE CLASSICS OF
THE FUTURE. WE SCOUT
FOR DESIGN TALENT AND
HANDPICK PRODUCTION
FACILITIES GLOBALLY. BUT
OUR ROOTS ARE STILL
NORDIC. WE RESPECT
NATURE THAT PROVIDE OUR
RAW MATERIALS, AND WE
BELIEVE IN DESIGN THAT IS
MADE TO LAST.





Le Corbusier
**POÈME
DE
L'ANGLE
DROIT**
Lithographies originales
Electa

RUBBER

LES ENFERMÉS

This table has one function more important than all others: To create joy.

MIA HAMBORG





PERNILLE VE
MCMLVII

KAI LIN
MCMLV

ARNE JA
MC

JØR
MC



ALBERT N. SABIN
MCMXVIII

ALBERT EINSTEIN
MCMXXVI

MIA FARROW
MCMXXVII

HOW WE PRODUCE

WE DARE TO CHALLENGE CONVENTION TO CREATE OBJECTS THAT RETHINK HOW WE USE MATERIALS AND MANUFACTURING TECHNIQUES. WE FIND BEAUTY IN OBJECTS THAT CAN BE CREATED BY THE LATEST INDUSTRIAL PROCESSES AS WELL AS THOSE THAT MAINTAIN TECHNIQUES THAT HAVE EVOLVED OVER A LONG TIME. WE PUSH MATERIALS TO THE LIMIT OF THEIR POTENTIAL AND RECONSIDER HOW THEY ARE PROCESSED TO CREATE A NEW AESTHETIC. WE STRIVE FOR TIMELESS BEAUTY AND QUALITY THAT IS BORN OUT OF TRADITION AND REVOLUTION.





“The main purpose of my work is to provoke people into using their imagination. Most people spend their lives living in dreary, grey-beige conformity, mortally afraid of using colours. By experimenting with lighting, colours, textiles and furniture and utilizing the latest technologies, I try to show new ways, to encourage people to use their phantasy imagination and make their surroundings more exciting”.

VERNER PANTON







MASS LIGHT

BY NORM ARCHITECTS

When traveling cities such as Paris, Barcelona and New York, NORM architects Kasper Rønn and Jonas Bjerre-Poulsen were fascinated by the street lamps; the characteristic cast iron top - looking a bit like a hat - with a semi transparent glass sphere at the base. Back in the studio NORM detached the street lamps from its original use and transferred the shape and combination of materials in order to design an outstanding, indoor pendant - the MASS LIGHT.



HOOF TABLE

BY SAMUEL WILKINSON

The word 'hoof' originates from the protective part of the feet of ungulate animals. In contrast to most tables, the leg ends of HOOF are left in natural wood so avoid the paint from chipping off from being either kicked or knocked when cleaning. The main inspiration for Samuel Wilkinson's HOOF LOUNGE TABLE derives from the feet which are shapened at the ends producing a striking yet functional detail. The foot detail is created by reversing the usual manufacturing process. Most furniture that have a painted section and a natural part are initially assembled, then masked off, and painted. HOOF stands out by being painted first and then trimmed back to reveal the natural grain.





I have always loved the painted wood chairs that have the leg ends left as natural wood so that the paint doesn't chip off from being either kicked or knocked when cleaning. The fine edge is created from the soft chamfer being on the top and bottom. This also gives the tables a tactile feel and clearly shows that the tables are made from solid wood.

SAMUEL WILKINSON



RAFT STOOL HIGH AND LOW

BY NORM ARCHITECTS

Maritime objects fascinate because of their contrasting surfaces. The roughness of corroded wood aging with beauty, blended with the industrial efficiency of metal structures. This is the inspiration behind the Raft Stool, created by NORM architects Kasper Rønn and Jonas Bjerre-Poulsen. They have taken a modern Scandinavian approach to create a unique piece of furniture that combines simplistic purity with a discreetly aged look. The sandblasted surface of the stool legs, accentuate the structure of the wood, while the triple legs have the playful appearance of a living creature in motion.





SHUFFLE TABLE

BY MIA HAMBORG

Mia Hamborg gives new life to the old Nordic craft tradition of turning wood by adding the colour and playful forms from old painted wooden toys. It's up to you where you want to put this fine piece of furniture and being truly Nordic and democratic, you can even decide the form, colours and height of the table.







The spinning-top toy, a childhood favourite, inspires to the joyful form of the Spinning Light along with the process of metal spinning. Here, form truly meets function in an innovative way. It's sleek, it's sexy and it's sure to become a new classic.



SPINNING LIGHT

BY BENJAMIN HUBERT

RAFT TABLE

BY NORM ARCHITECTS

Maritime objects fascinate because of their contrasting surfaces. The roughness of corroded wood aging with beauty, blended with the industrial efficiency of metal structures. This is the inspiration behind the Raft Table, created by NORM architects Kasper Rønn and Jonas Bjerre-Poulsen. They have taken a modern Scandinavian approach to create a unique piece of furniture that combines simplistic purity with a discreetly aged look. The sandblasted surface of the table legs, accentuate the structure of the wood, while the triple legs have the playful appearance of a living creature in motion.





Tivoli Lamp

As part of the Scandinavian tradition and inspired by Nordic sceneries, natural materials with a touch of poetry, combined with rationality characterise the NORM expression. In addition to beautiful workmanship and aesthetic simplicity, the essence of viability and long lasting products lies in keeping an uncensored relationship with nature.

NORM ARCHITECTS



BLASTED

BY KAI LINKE

The Blasted lamp is cut out of one single piece of wood to make as clean and simple a shape as possible. There's no cutting or gluing the wood together. The glass-blasted treatment of the wood is where the lamp takes its name from. Kai Linke was also thinking about what a flying branch would look like if it could be suspended in the air. He wanted to explore unexpected gravity. Can wood find a balance where normally no balance exists? The result is an asymmetrical pendant lamp.





To Jørn Utzon, his father's naval engineering drawings became a lifelong fascination with ships and boats, along with light. More than a decade before Jørn Utzon created his masterpiece, the Sydney Opera House, he put his childhood fascination into this pendant, combining successfully the smoothness of the lines of a ship with the source of light for the first time.

TIVOLI

BY JØRN UTZON



The intent of the Trash Me lamp is to create a product that is born from the trash and returned to the trash after a useful life.

VICTOR VETTERLEIN



ga koreografer på Stadsteatern 5 maj 19.30



FLOWERPOT VP3

BY VERNER PANTON



In 1968 the students' revolts in Paris, Rome and the United States were overthrowing stiff, old values, and initiating the Flower-Power generation of peace, love and harmony. Same year, Stanley Kubrick pictured the future of the year 2001, featuring the Verner Pantan Chair, and man was soon to set foot on the moon. In the world of design, a colourful, playful pendant hung in restaurants and exhibitions, and very soon, in everybody's homes. The FlowerPot with its two semi-circular spheres facing each other has long proved its lasting design quality and is just as much a synonym of our time, too.

MEGA BULB

BY SOFIE REFER

With Mega Bulb, Sofie Refer lit up the new millennium and a new classic was blown. The shape refers to the first electrical light bulbs by using thick transparent glass. Sofie Refer continues an elegant Nordic tradition, adding her own passion and femininity. The small irregularities in the mouth blown glass make each of the pendants one of a kind and add the story of the glass master's personal efforts in changing sand, soda and chalk into a modern classic using a thousand year old method.



MILK

BY NORM ARCHITECTS

With MILK, the NORM architects Kasper Rønn & Jonas Bjerre-Poulsen find exciting new ways in an ancient Nordic tradition of wood and glass. Though perfectly suited as a lamp, MILK adds more than light to your home. MILK can be placed anywhere and lights up both body and soul and lets the mind drift off to the Zen of a Japanese Onsen.





Sometimes the simplest things are the most lasting and memorable, the Topan Pendant being a brilliant example. It was the first mass produced lamp by Verner Panton, later to be followed by the FlowerPot. Topan's simplicity and coolness proves to be of lasting value.

TOPAN

BY VERNER PANTON

HOW WE THINK

OUR NORDIC HERITAGE IS PART OF OUR IDENTITY, YET WE MAINTAIN A VERY GLOBAL PERSPECTIVE. WE CREATE PRODUCTS THAT HAVE INTERNATIONAL APPEAL BY WORKING WITH INTERNATIONAL DESIGNERS WHO DISPLAY AN ORIGINAL AND INNOVATIVE TALENT WE WORK WITH BOTH YESTERDAY'S MASTERS AND TODAY'S REBELS WHO SHARE AN ABILITY TO BE AVANT-GARDE IN THEIR TIME BECAUSE THEIR CREATIONS OFTEN BECOME THE CLASSICS OF THE FUTURE.

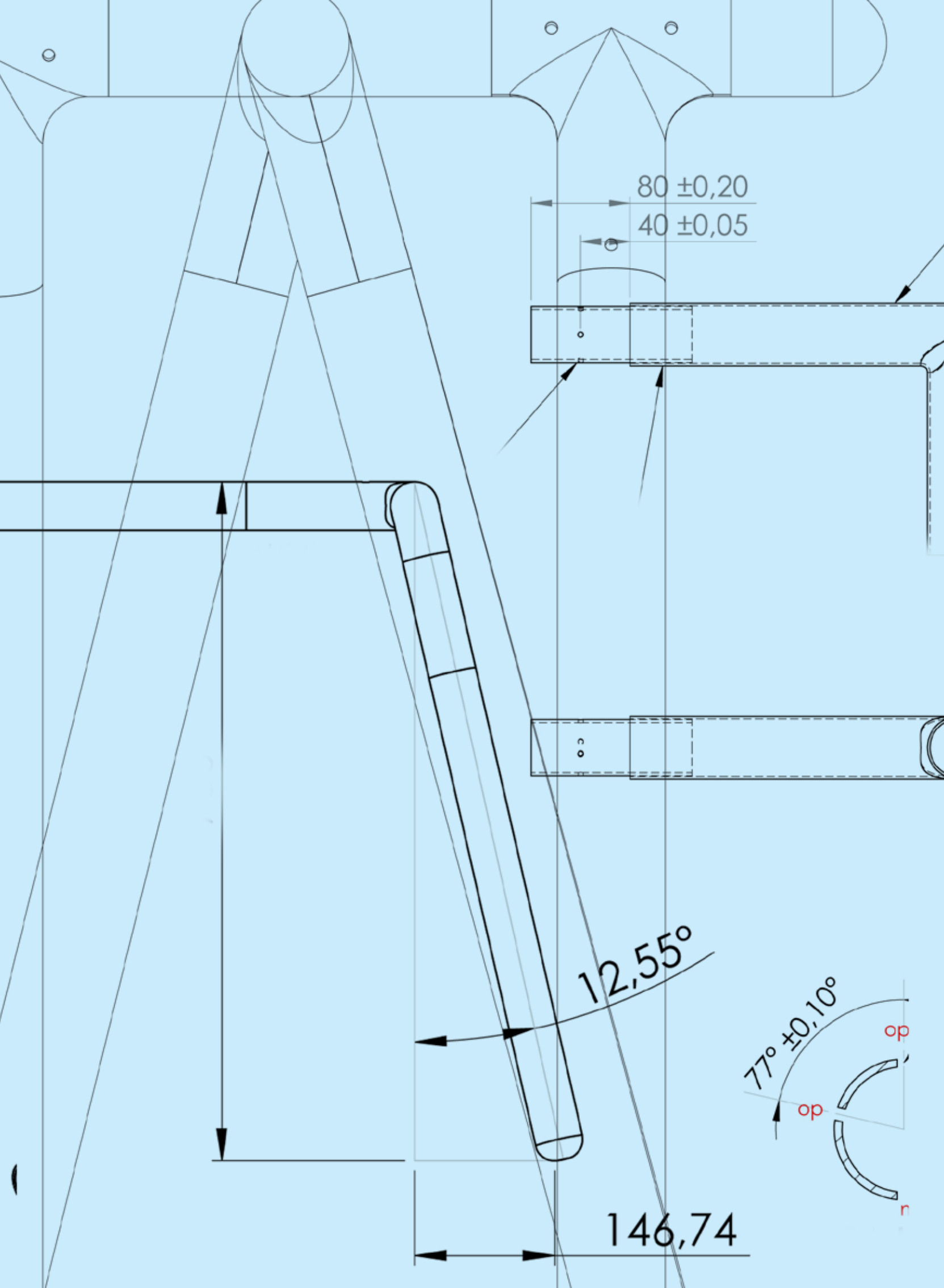

We wanted to redefine the bookshelf in an architectural and playful way. So we asked ourselves: What would a shelving system look like if playfulness and function was it's main values?

KIBISI







An object cannot become a design icon until it has stood the test of time and appears naturally in different settings. The awarded Flowerpot pendant is just that!

FLOWERPOT VP1 AND VP4

BY VERNER PANTON



Through globalization and the constant expansion of opportunity via the Internet, people are on the move and their interest and allegiance in all things is short-lived. The concept word for the Trash Me lamp design is transient. Like our current global culture, it is a product that is ephemeral. The lamp is made of paper pulp spread over a mold and left to dry. Paper is in itself a transient material. A strong concept idea leads to an extraordinary form, and in this case it is a rebirth of what the designer sees as the beauty of the utilitarian forms. It is only fitting that the name is Trash Me, meaning “please recycle me when no longer useful or desired”.

TRASH ME

BY VICTOR VETTERLEIN





SLICE

BY KIBISI

“What would a shelving system look like if playful customization was its main component?” This question urged the Danish design studio KiBiSi to design SLICE – an architectural redefinition of the continuous bookshelf. The main feature of the system is a slice of plywood. In assembly the slices fit together for individual display, which allows for optimum flexibility of the system and makes it adaptable from small to x-large. SLICE is a result of crossbreeding elements and attributes from different disciplines into a new design product made for every day use. & in a simple way SLICE reflects natural resource scarcity: No expensive mould, a simple playful idea, rework and the back-to-basics attitude of plywood.



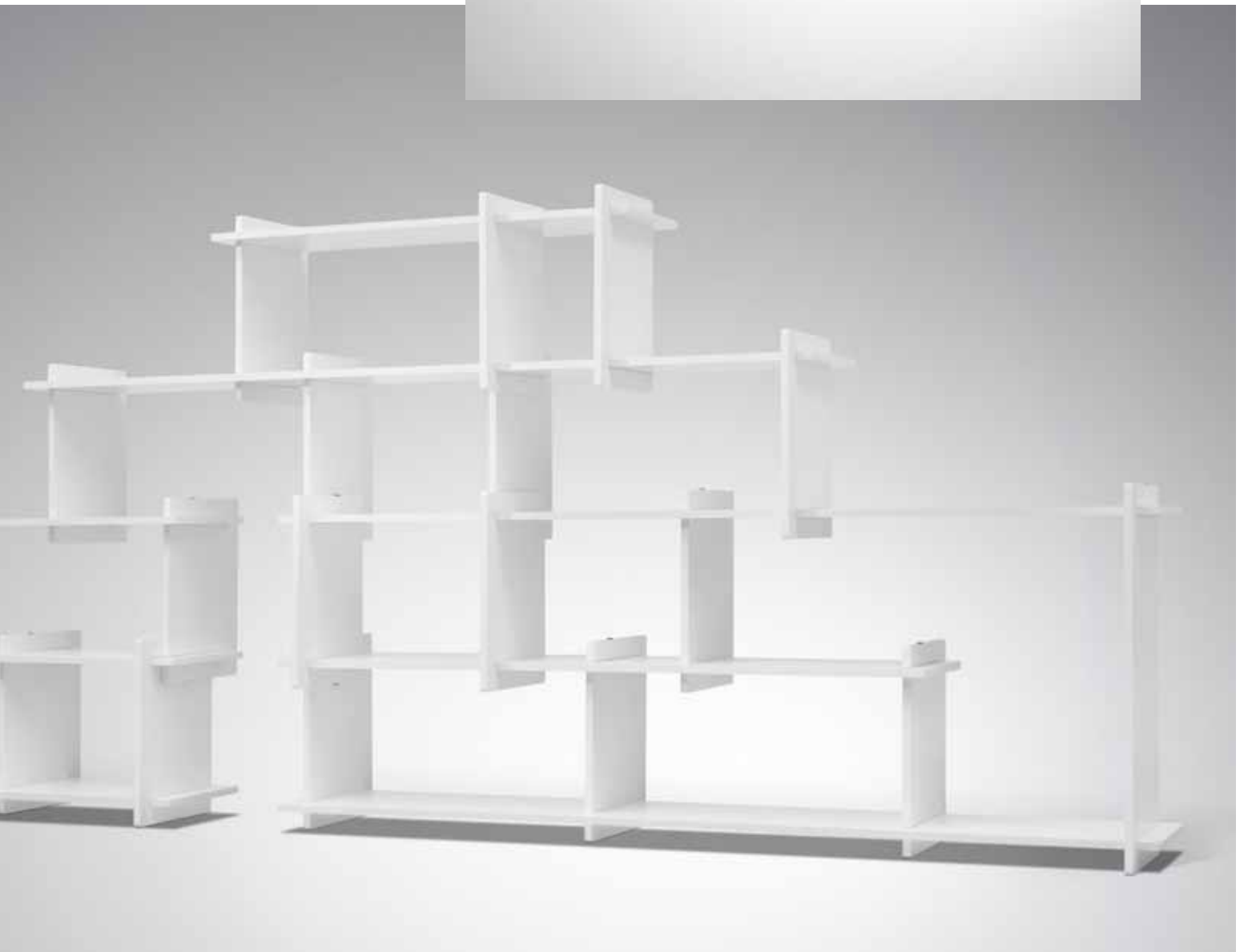



A LAMP BY
ARNE
JACOBSEN

PHILIP

DESIGNED
IN
1929

BELLEVUE

A LAMP BY **ARNE JACOBSEN**

DESIGNED IN 1929

It was a time of enlightenment. It was 1929. Arne Jacobsen designed his lamp to light up the experimental House of the Future. A breakthrough for modernism. Like the House of the Future, the Bellevue lamp combines rounded and sharp, straight lines. Simplistic, rational and created for the free human being. At a time before Arne Jacobsen became world famous. When his ideas on design were young and fresh. The Bellevue lamp is the light of early functionalism.



**BELLEVUE
AJ2**



**BELLEVUE
AJ3**



**BELLEVUE
AJ4**



HOUSE OF THE FUTURE

BY

ARNE JACOBSEN

THE BREAKTHROUGH
OF ARNE JACOBSEN.

THE VISIONARY
INTRODUCTION OF
MODERN ARCHITECTURE
IN DENMARK. IN THIS EYE
OPENING EXHIBITION

PROJECT, JACOBSEN
AND FLEMMING LASSEN
EXPLORED NEW

CIRCULAR LINES IN A
DYNAMIC COMPOSITION.

THEY INTEGRATED
GROUNDBREAKING
INVENTIONS, CREATING
REVOLUTIONARY
FUNCTIONAL FEATURES.

AND TO SHED LIGHT ON
THE VISION, JACOBSEN
DESIGNED THE CLASSIC
BELLEVUE LAMP.

THE HOUSE OF THE FUTURE
Winning project, 1929.
Drawing by Arne Jacobsen.



LIGHTING

FLOWERPOT VP1 BY VERNER PANTON



MATERIALS: Steel with lacquered finish and 3m matching fabric cord
DIMENSIONS: Ø: 230 x H: 160 mm
COLOURS: Black, White, Yellow, Red, Orange, Green, Chrome, Brushed, Purple, Turquoise, Mint, Blue
LIGHT SOURCE: 1x E27 max. 40 W or 7 W low energy bulb
DESIGN DATE: 1968



FLOWERPOT VP3 BY VERNER PANTON



MATERIALS: Steel with lacquered finish and 2m clear PVC cord
DIMENSIONS: Ø: 230 x H: 500 mm
COLOURS: Black, White, Yellow, Red, Orange, Chrome, Brushed, Mint, Turquoise, Purple
LIGHT SOURCE: 1x E27 max. 40 W or 7 W low energy bulb
DESIGN DATE: 1969



TOPAN VP6 BY VERNER PANTON



MATERIALS: Lacquered aluminium with 3m matching fabric cord
DIMENSIONS: Ø: 210 x H: 190 mm
COLOURS: Black, White, Yellow, Red, Orange, Turquoise, Green, Mint, Matt aluminium, Matt Black/Gold
LIGHT SOURCE: 1x E27 max. 40 W or 7 W low energy bulb
DESIGN DATE: 1959



SPINNING LIGHT BH2 BY BENJAMIN HUBERT



MATERIALS: Lacquered aluminium with 4m matching PVC cord
DIMENSIONS: Ø: 400x H: 340 mm
COLOURS: Black, White, Purple
LIGHT SOURCE: 1x E27 max. 60 W or 11 W low energy bulb
DESIGN DATE: 2010



BLASTED KL1 BY KAI LINKE



MATERIALS: Pine, polycarbonate, aluminium, and steel with 4 meter fabric cord
DIMENSIONS: H: 60 x L: 805 x W: 60 mm
COLOURS: Natural, Black
LIGHT SOURCE: 1x T5 (PK5) 549 mm Max: 14 W / 2700K
DESIGN DATE: 2011



BIG FLOWERPOT VP2 BY VERNER PANTON



MATERIALS: Steel with lacquered finish and 3m matching fabric cord
DIMENSIONS: Ø: 500 x H: 360 mm
COLOURS: Black, White, Yellow, Red
LIGHT SOURCE: 1 x E27 max. 100 W or 11 W low energy bulb
DESIGN DATE: 1971



FLOWERPOT VP4 BY VERNER PANTON



MATERIALS: Lacquered steel shade, polished steel stand and matching fabric cord
DIMENSIONS: Ø: 230 x H: 359 mm
COLOURS: Matt Black, White, Yellow, Green, Chrome, Red
LIGHT SOURCE: 1x E27 max. 40 W or 7 W low energy bulb
DESIGN DATE: 1969



SPINNING LIGHT BH1 BY BENJAMIN HUBERT



MATERIALS: Lacquered aluminium with 4m matching PVC cord
DIMENSIONS: H: 450 x Ø: 230mm
COLOURS: Black, White, Purple
LIGHT SOURCE: 1x E27 max. 60 W or 11 W low energy bulb
DESIGN DATE: 2010



TIVOLI JU1 BY JØRN UTZON



MATERIALS: Lacquered steel with 3m white fabric cord
DIMENSIONS: Ø: 220 x H: 230 mm
COLOURS: White, Chrome
LIGHT SOURCE: 1x E27 max. 40 W or 7 W low energy bulb
DESIGN DATE: 1947



CORIUM PV1 BY PERNILLE VEA



MATERIALS: Leather on aluminium, black with yellow stitches or tan with green stitches, 3 meter fabric cord
DIMENSIONS: H: 230 x Ø: 400 mm
COLOURS: Natural tan & green cord, Black leather & black cord
LIGHT SOURCE: Max. 75 W or 20 W low energy bulb
DESIGN DATE: 2008



BULB SR1 BY SOFIE REFER



MATERIALS: Clear mouth blown glass with 2,5 meter cord, porcelain lamp holder and ceiling rose
DIMENSIONS: H: 163 x Ø: 110 mm
CORD COLOURS: Red fabric, Black fabric, clear PVC
LIGHT SOURCE: 1x E27 max. 60 W or 11 W low energy bulb
DESIGN DATE: 2006

CORD COLOURS

MEGA BULB SR2 BY SOFIE REFER



MATERIALS: Clear mouth blown glass with clear 2,5 meter cord, porcelain lamp holder and ceiling rose
DIMENSIONS: H: 230 x Ø: 180 mm
CORD COLOURS: Red fabric, Black fabric, clear PVC
LIGHT SOURCE: 1x E27 max. 60 W or 11 W low energy bulb
DESIGN DATE: 2006

CORD COLOURS

BELLEVUE AJ3 BY ARNE JACOBSEN



MATERIALS: Lacquered aluminium shade with steel frame and 3 meter fabric cord
DIMENSIONS: Base: Ø: 195 mm. Lamp: D: 580 x H: 514 mm
COLOURS: White, Matt Black
LIGHT SOURCE: 1x E27 max. 60 W or 11 W low energy bulb
DESIGN DATE: 1929

BELLEVUE AJ2 BY ARNE JACOBSEN



MATERIALS: Lacquered aluminium shade with steel frame and 3 meter fabric cord
DIMENSIONS: Base: Ø: 273 mm. Lamp: D: 600 x H: 1120 mm
COLOURS: White, Matt Black
LIGHT SOURCE: 1x E27 max. 60 W or 11 W low energy bulb
DESIGN DATE: 1929

BELLEVUE AJ4 BY ARNE JACOBSEN



MATERIALS: Lacquered aluminium shade with steel frame and 3 meter fabric cord
DIMENSIONS: Wall Mount: Ø: 85 mm
Lamp: D: 420 x W: 195 x H: 337 mm
COLOURS: White, Matt Black
LIGHT SOURCE: 1x E27 max. 60 W or 11 W low energy bulb
DESIGN DATE: 1929

TRASH ME VV1 BY VICTOR VETTERLEIN



MATERIALS: Paper pulp, MDF and aluminium with 3 meter fabric cord.
DIMENSIONS: H: 524 x L: 254 x W: 165 mm
COLOURS: Pulp grey
LIGHT SOURCE: 1x E27 max. 40 W / 7 W low energy bulb
DESIGN DATE: 2010

HOTEL ROYAL AJ1 BY ARNE JACOBSEN



MATERIALS: Acrylic, glass and aluminium with 3 meter clear PVC cord
DIMENSIONS: W: 210 x L: 210 x H: 190 mm
COLOURS: Opal White, Transparent, Frosted White, Smoked, Cognac
LIGHT SOURCE: 1x E27 max. 60 W or 11 W low energy bulb
DESIGN DATE: 1961

MILK NA1 BY NORM ARCHITECTS



MATERIALS: Opal glass, plastic and untreated oak, with 2 meter fabric cord with dimmer switch.
DIMENSIONS: Ø: 200 x H: 250 mm
CORD COLOURS: Black, White
LIGHT SOURCE: 1x max. 40 W G9 halogen
DESIGN DATE: 2009

CORD COLOURS

MASS LIGHT NA5 BY NORM ARCHITECTS



MATERIALS: Marble stone/acid-etched opal glass, 5 meter fabric cord
DIMENSIONS: Ø: 126 x H: 183 mm
LIGHT SOURCE: 1x G9 - max. 40W
DESIGN DATE: 2012

MASS LIGHT NA6 BY NORM ARCHITECTS



MATERIALS: Marble stone/acid-etched opal glass, 5 meter fabric cord, lacquered steel canopy
DIMENSIONS: Ø: 126 x H: 183 mm
LIGHT SOURCE PER LAMP: 1x G9 max. 40W
LAMPS INCLUDED: 9
DESIGN DATE: 2012

FURNITURE

RAFT TABLE NA2 BY NORM ARCHITECTS



MATERIALS: powdercoated steel with solid oak legs. Table top in white laminated wood or black ash veneer
DIMENSIONS: H: 740 mm x D: 900 mm x L: 2400 mm
COLOURS: Black with black ash, White with natural oak
DESIGN DATE: 2011



RAFT STOOL NA3 BY NORM ARCHITECTS



MATERIALS: powdercoated steel with solid oak or ash legs. Seat in sandblasted oak or black ash
DIMENSIONS: H: 460 mm x D: 450 mm x W: 500 mm
COLOURS: Black with black ash, White with natural oak
DESIGN DATE: 2011



RAFT BARSTOOL NA4 BY NORM ARCHITECTS



MATERIALS: powdercoated steel with solid oak or ash legs. Seat in sandblasted oak or black ash
DIMENSIONS: H: 700 mm x D: 450 mm x W: 560 mm
COLOURS: Brass with black ash, Brass with natural oak
DESIGN DATE: 2011



SHUFFLE TABLE MH1 BY MIA HAMBORG



MATERIALS: Lacquered MDF, solid oak & beech
DIMENSIONS: Ø: 450 x H: 690 mm
COLOURS: Multicolour
DESIGN DATE: 2010

HOOF LOUNGE TABLE SW1 BY SAMUEL WILKINSON



MATERIALS: Solid oak, brushed surface
DIMENSIONS: Ø: 500 x 500
COLOURS: Grey, Black & Naturel oak
DESIGN DATE: 2012



SHUFFLE TABLE MH1 BY MIA HAMBORG



MATERIALS: Lacquered MDF, solid oak & beech
DIMENSIONS: Ø: 450 x H: 690 mm
COLOURS: Black marble stone
DESIGN DATE: 2010

HOOF LOUNGE TABLE SW2 BY SAMUEL WILKINSON



MATERIALS: Solid oak, brushed surface
DIMENSIONS: Ø: 900 x 400
COLOURS: Black & Natural oak
DESIGN DATE: 2012



SLICE SHELF SMALL KB 1 BY KIBISI



MATERIALS: Birch plywood
DIMENSIONS: Boards: 1 pcs 1160x360x20 & 3 pcs 2200x360x20
Columns: 8 pcs 719x360x20 & 2 pcs 349x360x20
COLOURS: White lacquered
DESIGN DATE: 2012



SLICE SHELF SMALL KB 3 BY KIBISI



MATERIALS: Birch plywood
DIMENSIONS: Boards: 2 pcs 2200x360x20 & 3 pcs 1680x360x20 & 2 pcs 1160x360x20 & 2 pcs 640x360x20
Columns: 20 pcs 860x360x20 & 4 pcs 490x360x20
COLOURS: White lacquered
DESIGN DATE: 2012



SLICE SHELF SMALL KB 2 BY KIBISI



MATERIALS: Birch plywood
DIMENSIONS: Boards: 2 pcs 2200x360x20 & 1 pcs 1680x360x20 & 2 pcs 1160x360x20 & 1 pcs 640x360x20
Columns: 4 pcs 860x360x20 & 14 pcs 490x360x20
COLOURS: White lacquered
DESIGN DATE: 2012



COLOURS

CHROME **C**

BRUSHED **B**

YELLOW 

ORANGE 

RED 

COGNAC 

PURPLE 

MINT 

GREEN 

TURQUOISE 

BLUE 

WHITE 

GREY 

BLACK 

MATT BLACK **M**

TRANSPARENT **T**

FROSTED **F**

SMOKED **S**

MATT BLACK/GOLD 

WHITE/NATURE 

NATURE 



DOWNLOAD FREE QR
READER FROM APP STORE

&TRADITION

KONGEVEJEN 2
DK-3480 FREDENSBORG
PHONE +45 3920 0233
FAX +45 3920 0256
INFO@ANDTRADITION.DK

VISIT
US
AT
ANDTRADITION.COM