

# Pressalit Care Wet Floor Formers

Preformed bases for completely level access showering  
Version 4



●  
keep living

# Pressalit Care Wet Floor Formers

The range of six preformed bases ensures that the correct falls are automatically created – average gradient 20 mm to the drainage outlet – coupled with optional waste positions, achieved by rotating the former, designed to create a truly unhindered showering area.



## Automatic pump activation

Pressalit Care offers a unique method of waste pump activation. This enables any water discharged into the waste outlet to be automatically removed without the need for a flow switch. This facility is also available with the new wet floor formers.

In conjunction with the Whale Gulper pump and together with the multi-speed setting transformer, it allows the pump operation to be matched to the requirements of the installation ensuring the lowest possible noise levels are achieved.

A flow switch operated pump option is also available.

## Design features

Huge 20mm preformed gradient to the waste outlet for swift water dispersal.

Trimable edges to all four sides of the former to allow the maximum flexibility in installation where site restrictions and obstacles prevent full size installation.

A full 30mm flat area, even after trimming, to the complete surround of the former ensures an excellent water seal for the shower doors.

A textured surface to the former to aid adhesion of flooring coverings.

Can be used in conjunction with the extensive range of Pressalit Care door options.

Larger formers ideally suited to the Rise'n'Glide variable length screens where finished size is not predictable.

All formers are available with optional waste gullies for gravity or pumped waste outlet installations.

## Materials

Manufactured from toughened Glass-Reinforced Plastic (GRP) for strength and durability, whilst also being light and easy to install.

## Load

Pressalit Care Wet Floor Formers can safely take a loading of up to 30 Stone (190 kg), catering for the weight of both a wheelchair user and a carer.

## Guarantee 15 Years

Pressalit Care guarantees to remedy material and manufacturing defects for a period of 15 years from the invoicing date. (Excludes pump).

### Wet Floor Formers – Square

- Former L x W: 900 x 900 mm E03ET02
- Former L x W: 1000 x 1000 mm E03ET03
- Former L x W: 1200 x 1200 mm E03ET04

The square wet floor formers can all be trimmed by up to 50mm on each of the four sides. The underside of the former is marked with a 'Max Trim Line' to assist trimming and will still enable the correct location of shower screens used to complete the installation.

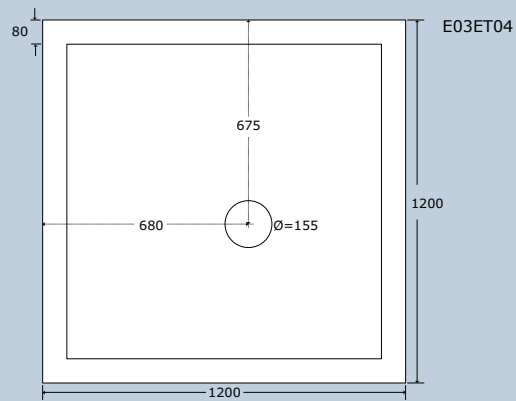
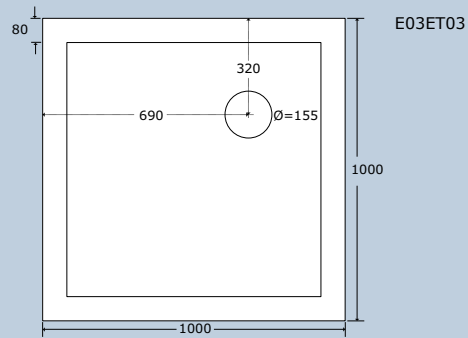
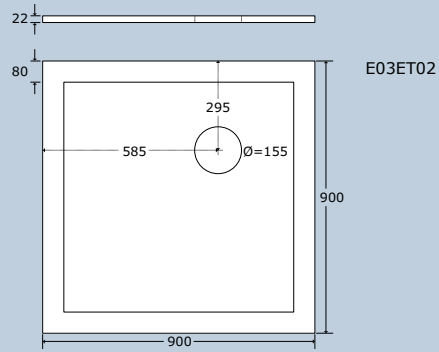

### Accompanying products

#### Door

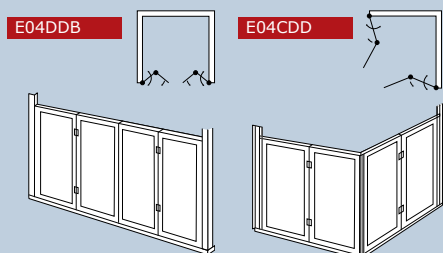

#### Rise'n'Glide Screens 2/3 panels

- Left hinged E04RGW2LH
- Right hinged E04RGW2RH

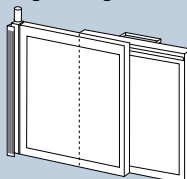

- Left hinged E04RGW3LH
- Right hinged E04RGW3RH

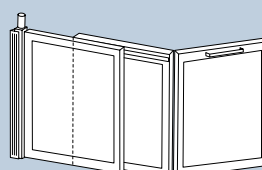

#### W2 portfolio

- 1000 x 1000 mm W2/ET03
- 1200 x 800 mm W2/ET05

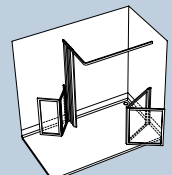

#### NB:

All measurements are in mm.

### Wet Floor Formers – Rectangular

- Former L x W: 1200 x 800 mm E03ET05
- Former L x W: 1500 x 800 mm E03ET06
- Former L x W: 1800 x 850 mm E03ET07

The smaller of the three rectangular wet floor formers (E03ET05) can be trimmed by up to 50 mm on each of the four sides.

The two larger wet floor formers (E03ET06 & E03ET07) can be trimmed by up to 50 mm on each of the long sides and up to 75 mm on each of the short sides.

The underside of the former is marked with a "Max Trim Line" to assist trimming and will still enable the correct location of the shower screens used to complete the installation.

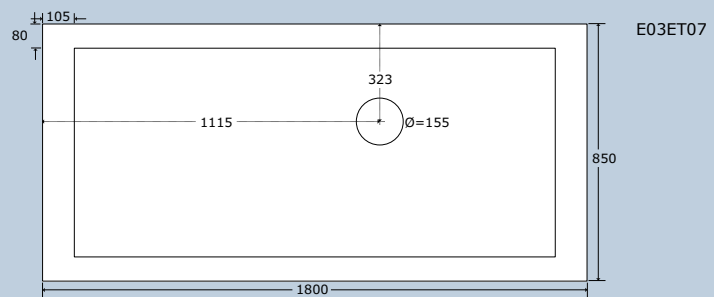
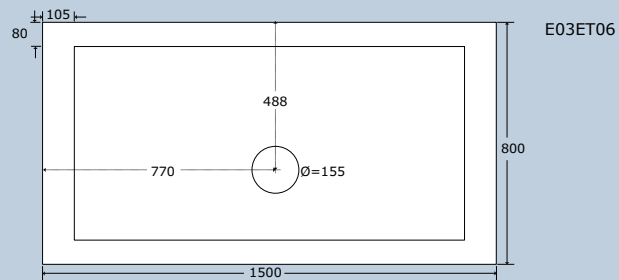
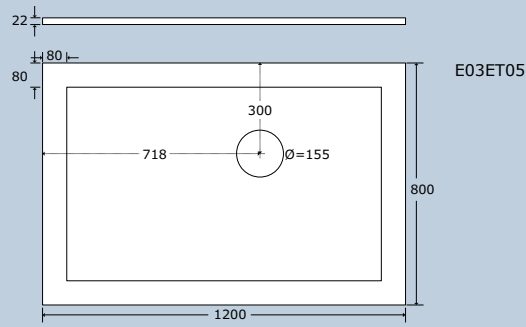

### Wet Floor Formers – Waste Options

- Gravity waste with 75 mm seal D13TSG1WH
- Gravity waste with 50 mm seal D13TSG50W
- Pumped waste for use with flow switch (does not include pump) D13USG1WH
- Pumped waste kit for use with probes (includes pump, transformer and fittings) D13PPK1WH

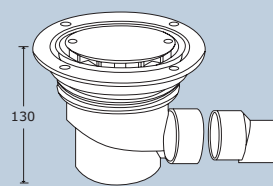

D13TSG1WH

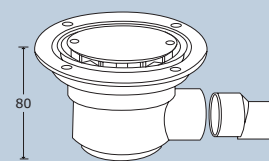

D13TSG50W

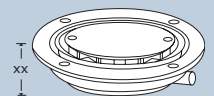

D13USG1WH

### Seat

- With back E07MMA043
- Without back E07MMA051

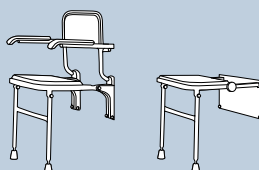

### Grab Rails

- Grab rail 306 mm R1352xxx
- Grab rail 459 mm R1353xxx
- Grab rail 612 mm R1354xxx

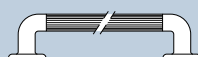

### Curtains and Rails

- Straight curtain rail E12SCRAIL
- L-shaped curtain rail E12LCRAIL
- U-shaped, curtain rail E12UCRAIL
- White curtain D09MPWH84
- Chequered curtain D09MP3084

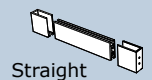

Straight

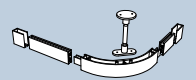

L-shape

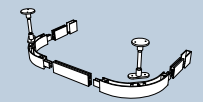

U-shape

xxx denotes colour option as below

- 000 White
- 035 Red RAL3003
- 108 Dark blue RAL5011

# Technical information

A quick, simple and cost effective means of creating a wet floor area, in both concrete and timber floors. The average 20 mm preformed gradient saves time and labour in creating difficult falls.



Range of sizes, all trimmable, available to suit most installation requirements.

Formers are lightweight making both handling and installation easy.

Turn around time savings for concrete floors waiting for screed drying times.

Formers have a textured surface, alleviating the need for further surface preparation to aid adhesion to most proprietary vinyl safety flooring e.g. Altro.

Designed to be installed in both timber and concrete floors.

Tray rotation to allow ease of selection for waste outlet position. Often required where joist locations are unknown until installation.

In timber floor installations, can be placed directly and secured onto floor joists.

Overall tray depth is 22mm allowing ease of installation with standard timber floors and plywood overboard.

**Pressalit Care plc**  
Potts Marsh Industrial Estate  
Eastbourne Road  
Westham, East Sussex BN24 5NH

Tel. + 44 (0) 844 880 6950  
Fax + 44 (0) 844 880 6951

E-mail [uksales@pressalitcare.com](mailto:uksales@pressalitcare.com)  
Web [www.pressalitcare.co.uk](http://www.pressalitcare.co.uk)

A division of Pressalit Group A/S

CBI101C 09.09

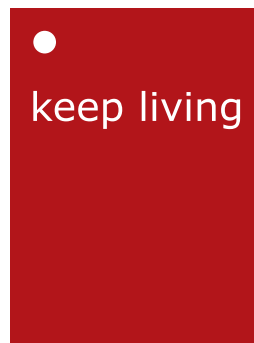

Pressalit Care is a subsidiary of the Danish company Pressalit Care.

Pressalit Care is a leader in furnishings for persons with physical disabilities. The philosophy is that impaired mobility need not limit a person's life. Our solutions for kitchens and bathrooms take this fundamental idea down to the smallest detail.

We offer 30 years of experience in the healthcare industry and have worldwide operations.

**[www.pressalitcare.com](http://www.pressalitcare.com)**